

PARALLEL ARM INSTALLATION
CLOSER MOUNTED ON DOOR ON PUSH SIDE

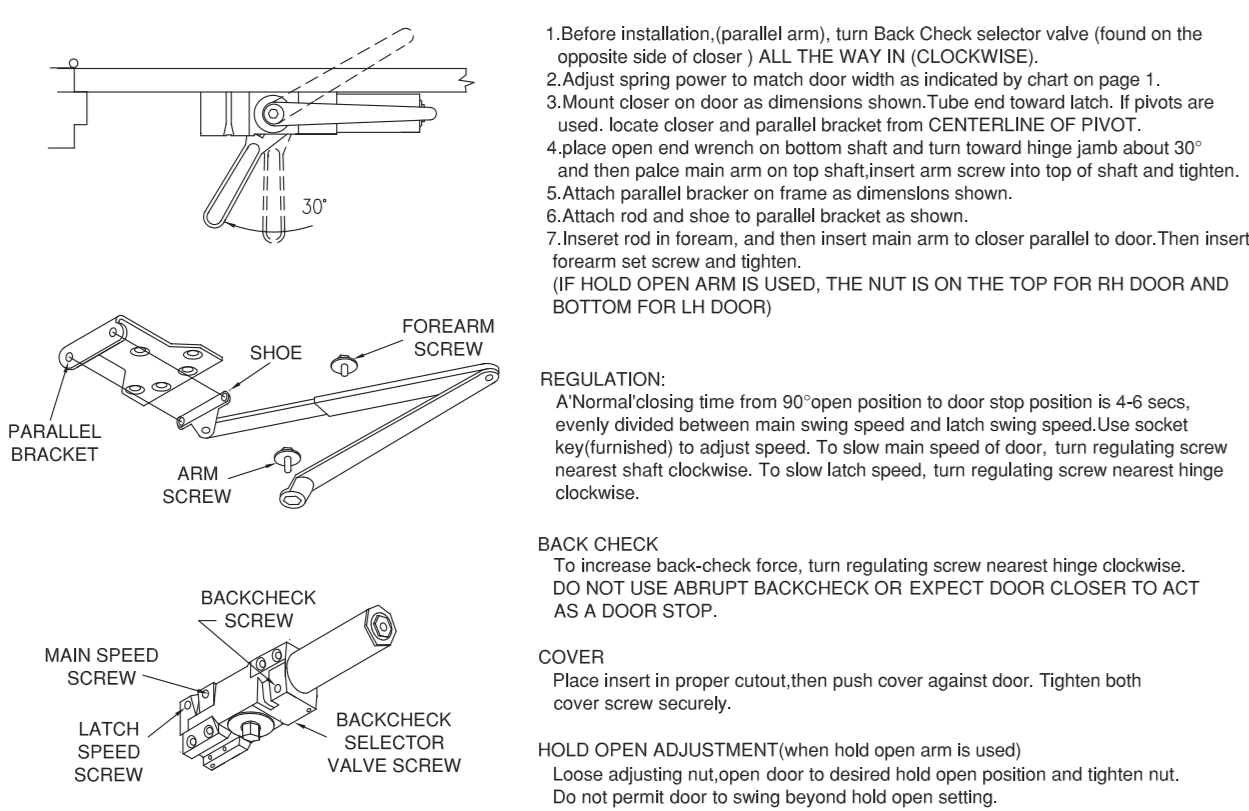

DOOR CLOSER
INSTALLATION INSTRUCTION

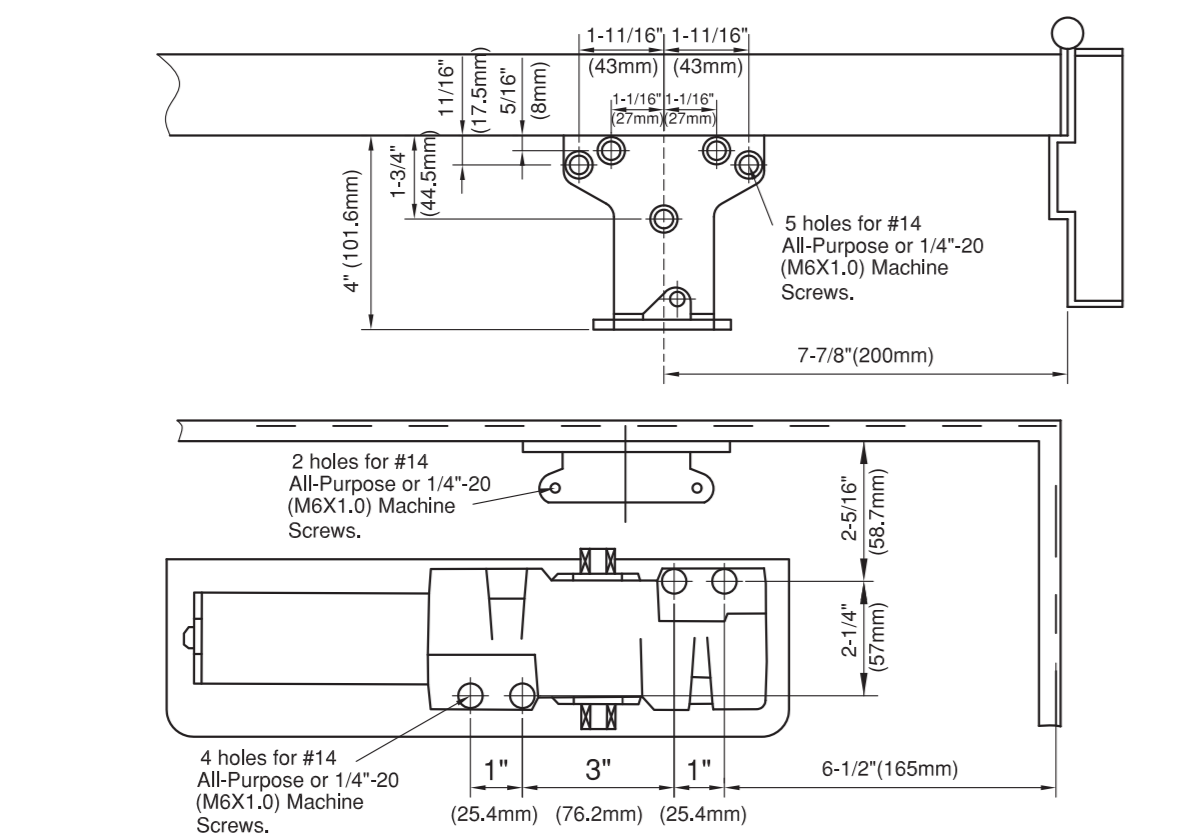
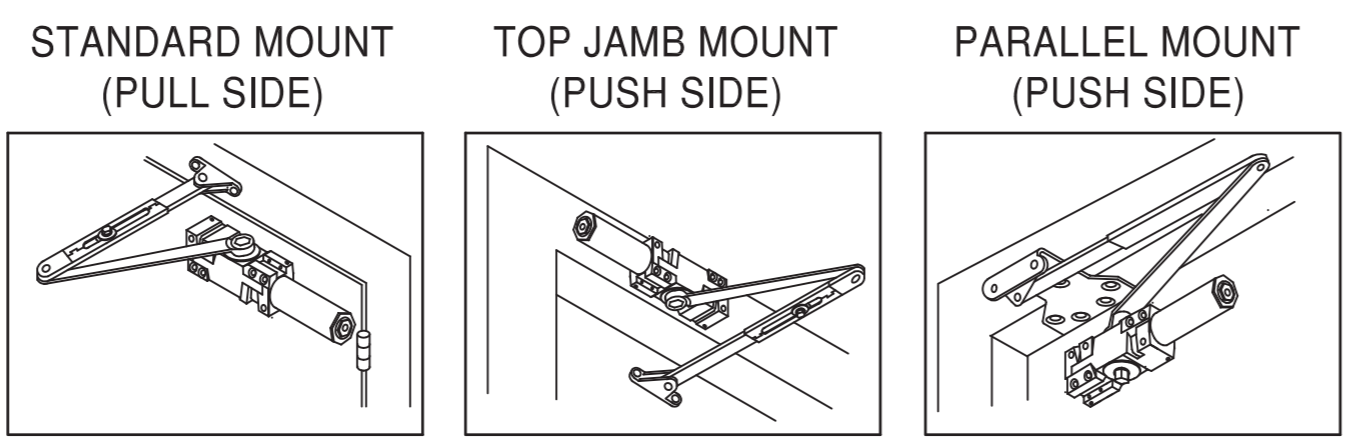

MAXIMUM DOOR WIDTH		FULL TURNS REQUIRED
EXTERIOR DOORS	INTERIOR DOORS	
8.5 lb-ft	34" (864)	5 TURNS C.C.W.
30" (762)	38" (962)	0 TURNS
36" (914)	48" (1219)	5 TURNS C.W.
42" (1067)	54" (1372)	10 TURNS C.W.
48" (1219)	60" (1524)	15 TURNS C.W.

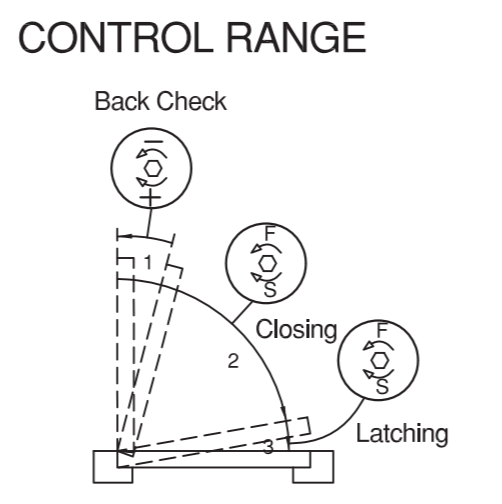
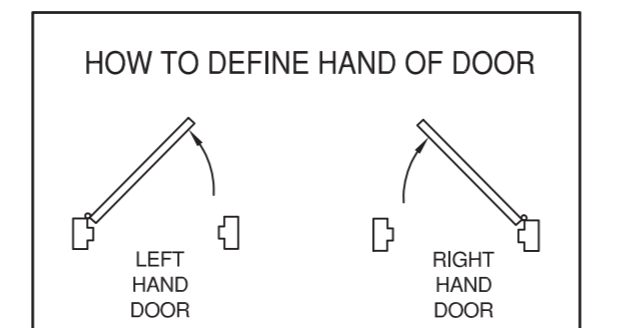

Spring Power Adjustment

STANDARD INSTALLATION
CLOSER MOUNTED ON DOOR ON PULL SIDE

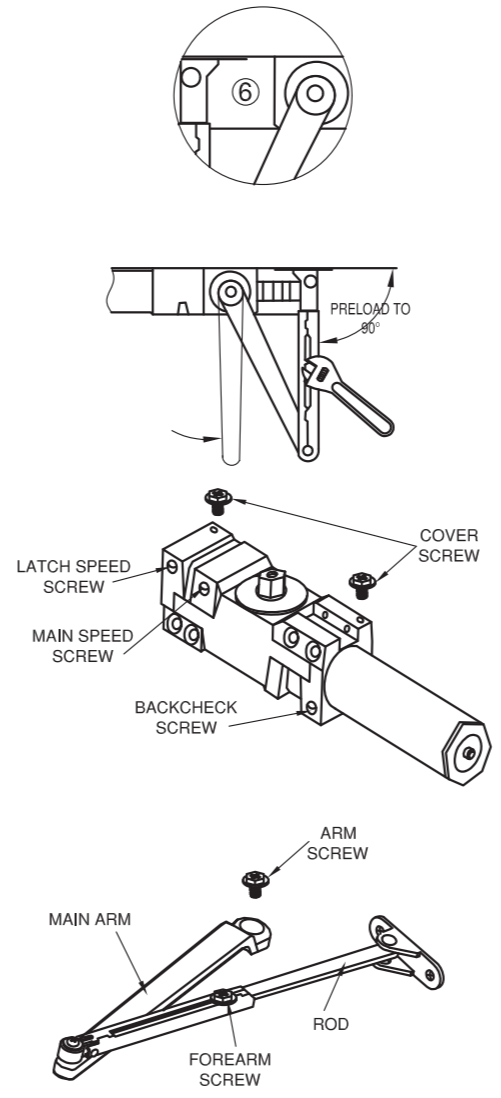
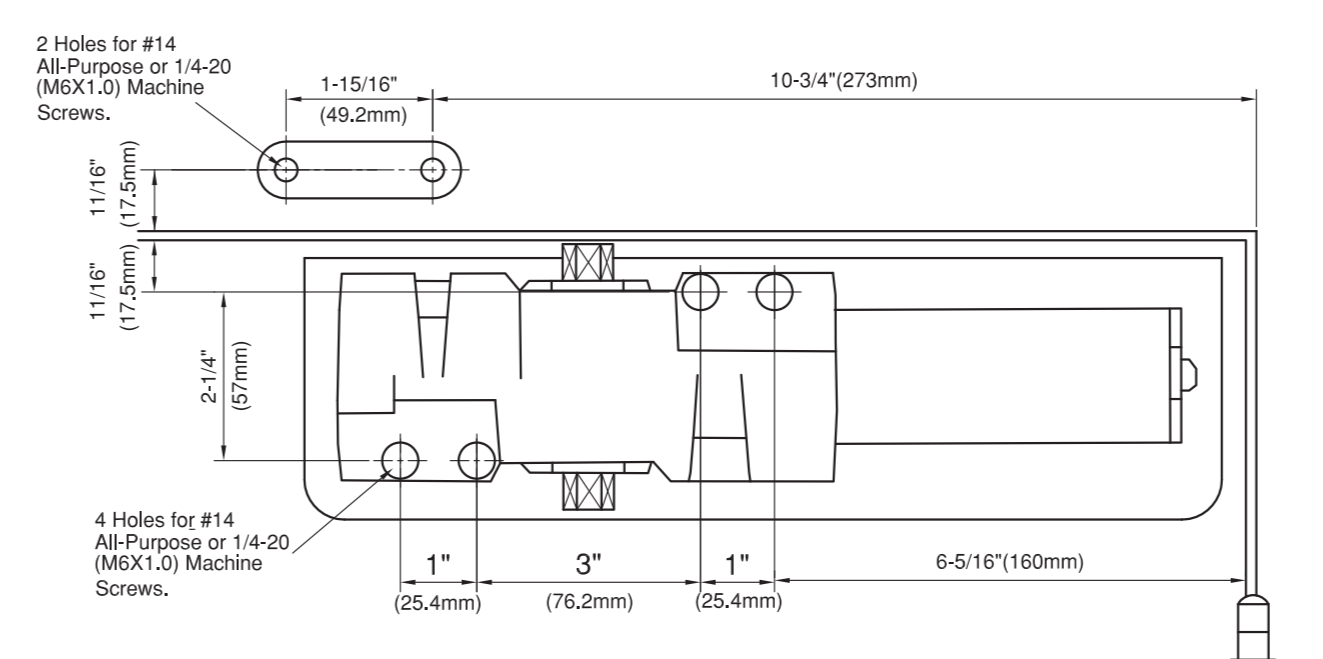

1. Adjust spring power to match door width as indicated by chart on page 1.
 2. Mount closer on door as dimension shown. Tube end toward hinge. If pivots are used, locate closer and shoe from CENTERLINE OF PIVOT.
 (For offset pivots, pls increase the marked dimensions by 1/8")
 3. Place main arm on top of shaft 100° to closer body, insert arm screw into top of shaft and tighten.
 4. Attach shoe to door as shown. (If more latching power is required, rotate shoe 180°)
 5. Open door and insert rod in forearm.
 6. With forearm at right angle to door (90°), insert forearm set screw and tighten.
 (IF HOLD OPEN ARM IS USED, THE NUT IS ON THE TOP FOR RH DOOR AND BOTTOM FOR LH DOOR)

REGULATION:
 A Normal closing time from 90° open position to door stop position is 4-6 secs, evenly divided between main swing speed and latch swing speed. Use socket key (lurnished) to adjust speed. To slow main speed of door, turn regulating screw nearest shaft clockwise. To slow latch speed, turn regulating screw nearest hinge clockwise.

BACK CHECK
 To increase back-check force, turn regulating screw nearest hinge clockwise. DO NOT USE ABRUPT BACKCHECK OR EXPECT DOOR CLOSER TO ACT AS A DOOR STOP.

COVER
 Place insert in proper cutout, then push cover against frame. Tighten both cover screw securely.

HOLD OPEN ADJUSTMENT (when hold open arm is used)
 Loose adjusting nut, open door to desired hold open position and tighten nut. Do not permit door to swing beyond hold open setting.

TOP JAMB INSTALLATION
CLOSER MOUNTED TOP JAMB ON PUSH SIDE OF DOOR

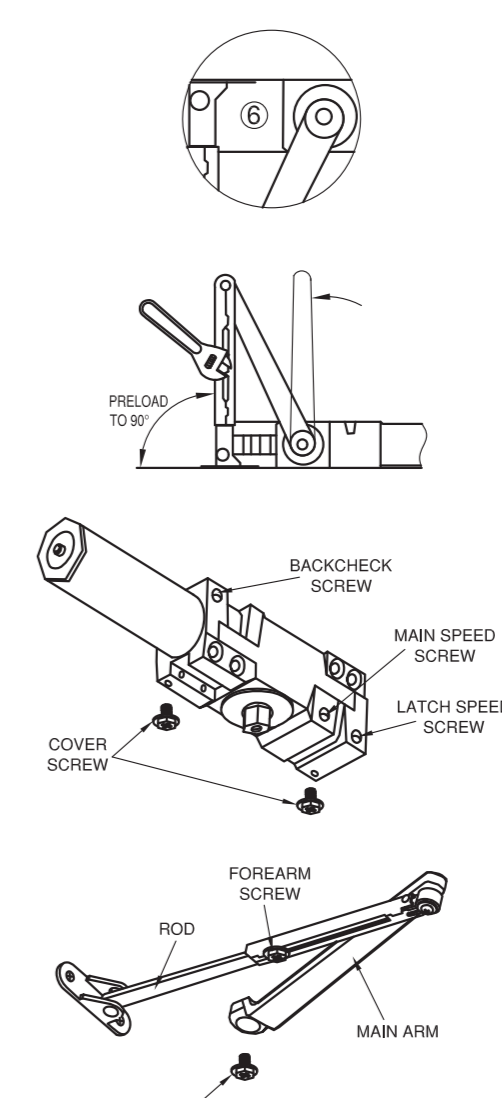
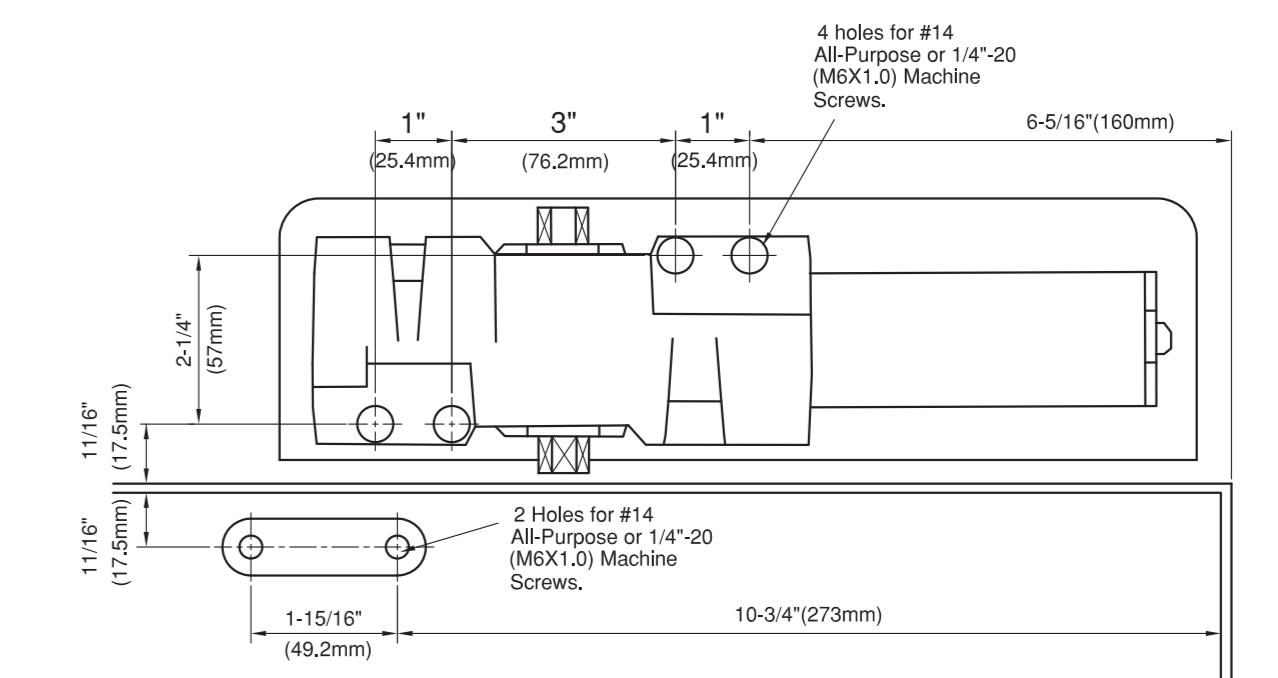

1. Adjust spring power to match door width as indicated by chart on page 1.
 2. Mount closer on frame as dimension shown. Tube end toward hinge. If pivots are used, locate closer and shoe from CENTERLINE OF PIVOT.
 (For offset pivots, pls increase the marked dimensions by 1/8")
 3. Place main arm on top of shaft 100° to closer body, insert arm screw into top of shaft and tighten.
 4. Attach shoe to door as shown. (If more latching power is required, rotate shoe 180°)
 5. Open door and insert rod in forearm for reveal 2.5\"/>

REGULATION:
 A Normal closing time from 90° open position to door stop position is 4-6 secs, evenly divided between main swing speed and latch swing speed. Use socket key (lurnished) to adjust speed. To slow main speed of door, turn regulating screw nearest shaft clockwise. To slow latch speed, turn regulating screw nearest hinge clockwise.

BACK CHECK
 To increase back-check force, turn regulating screw nearest hinge clockwise. DO NOT USE ABRUPT BACKCHECK OR EXPECT DOOR CLOSER TO ACT AS A DOOR STOP.

COVER
 Place insert in proper cutout, then push cover against frame. Tighten both cover screw securely.

HOLD OPEN ADJUSTMENT (when hold open arm is used)
 Loose adjusting nut, open door to desired hold open position and tighten nut. Do not permit door to swing beyond hold open setting.