

END LOADING

TOP DOOR RAIL

"A" Type End Loading Arm

Make a 1"(25.4mm) deep cut-out in hinge edge of door as shown.

"PT" Type End Loading Arm

Make a 7/8"(22mm) deep cut-out in hinge edge door as shown.

Drill or drill and tap holes in top of door as shown.

Position arm in door by placing arm pin in 3/16"(5mm) hold. Install arm using three 1/4-20x5/8"(M6x1.0) pan head machine screws and lock washers. Center arm in the top rail by adjusting the two 1/4-20x1"(M6x1.0) hex head centering bolts.

NOTE: After door is install ,the two 1/4-20 x1"(M6x1.0) socket head clamp bar cap screws the with lock washers must be tightened securely

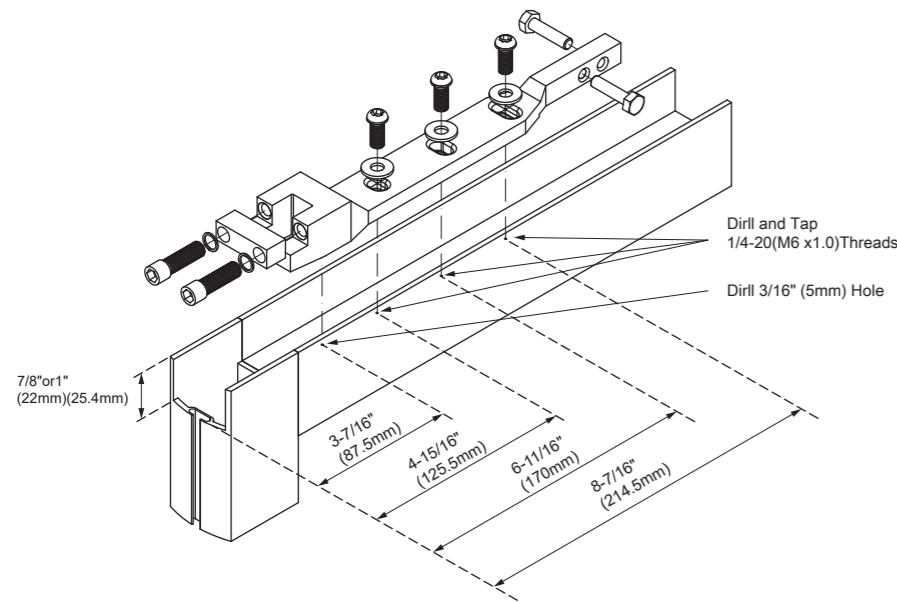

BOTTOM DOOR RAIL

End Loading

Make cut out in hige edge of door equal to depth of bottom rail as shown.

Drill and tap 1/4-20(M6x1.0) holes in bottom rail of door as shown .Install pivot bearing retainer in bottom of door using 1/4-20x5/8"(M6x1.0) pan head machine screws and lock washer.

Laterally adjust center of pivot bearing re-tainer 2-5/8"(66.5mm)(or 2-11/16",68mm) form hige edge of door (not including weatherstripping) and tighten screws securely.

NOTE: For doors with 1"(25.4mm) bottom shortened by sawing off at score 1/2"(12.5mm) from bottom.

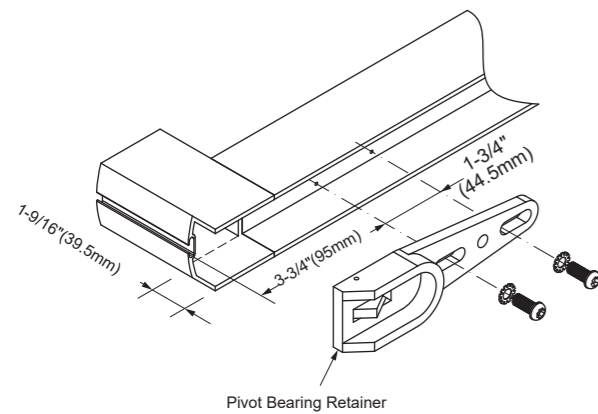

TOP DOOR RAIL

"K" Type End Loading Arm

Make a 5/8"(16mm) deep cut-out in hige edge of door as shown.

Drill or drill and tap holes in to[of door as shown.

Poistion arm in door by placing arm pin in 1/4(6.5mm) hole .Install arm by using two 1/4-20x5/8"(M6x1.0) pan head machine screws and lock washers. Center arm in the top rail by adjusting the two 1/4x20x1"(M6x1.0) hex head centering bolts.

NOTE : After door is intalled, the two 1/4-20x1"(M6x1.0)socket head clamp bar cap screws with lock washers must be tightened securely.

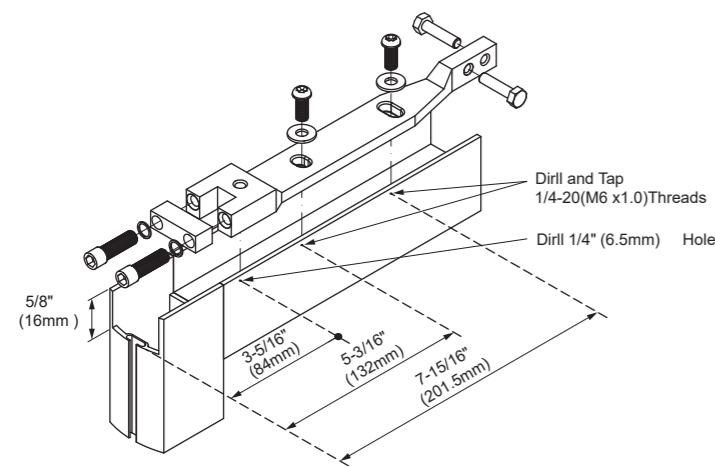

SERIES 60
"CONCEALED OVERHEAD"
INSTALLATION INSTRUCTIONS

DOUBLE OR SINGLE ACTING-CENTER HUNG-SIDE AND END LOADING
DUAL SPEED ADJUSTING VALVES FOR LATCHING
AND CLOSING SPEED ADJUSTMENT

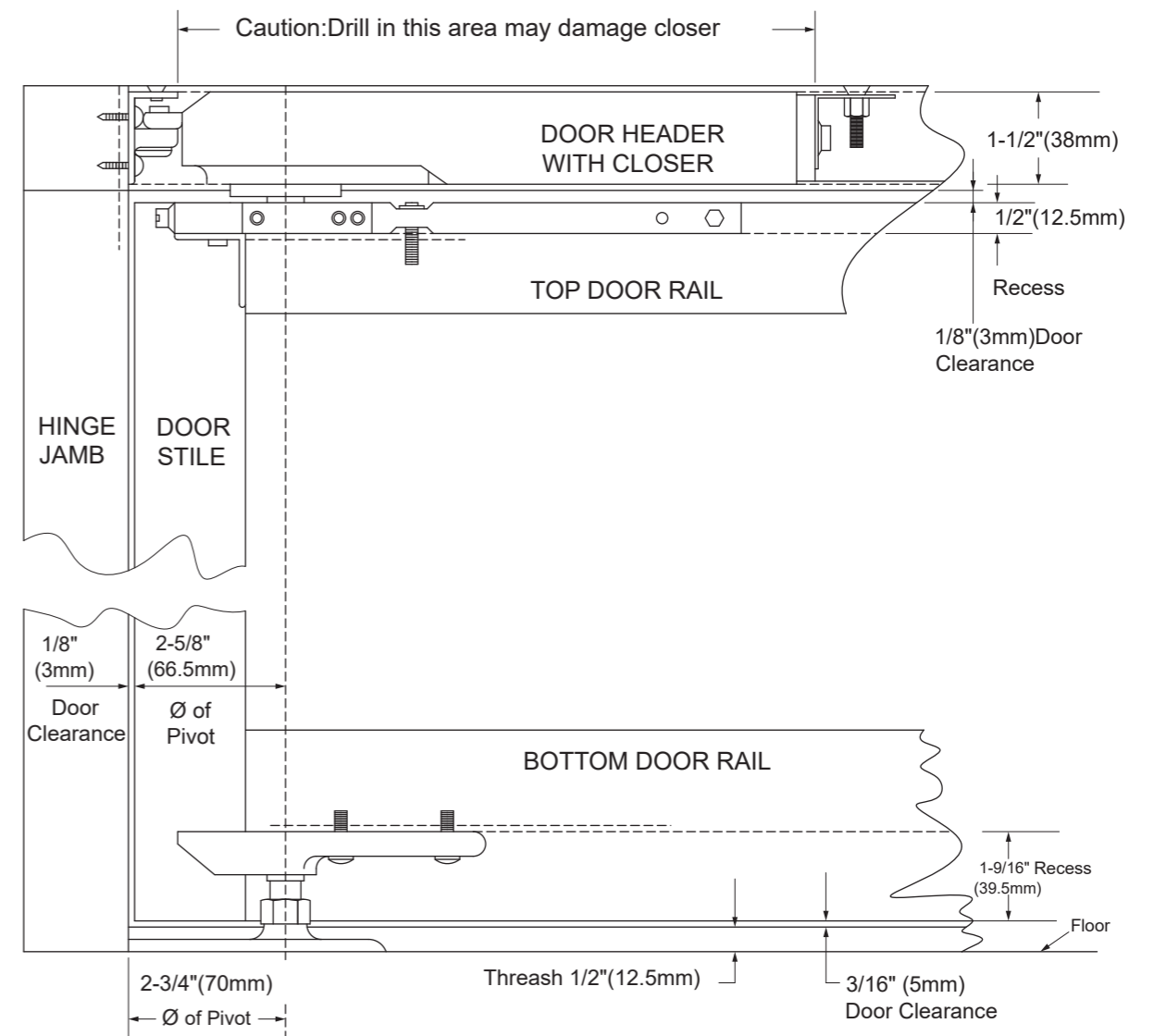

HOW TO REGULATE CLOSING AND LATCHING SPEED

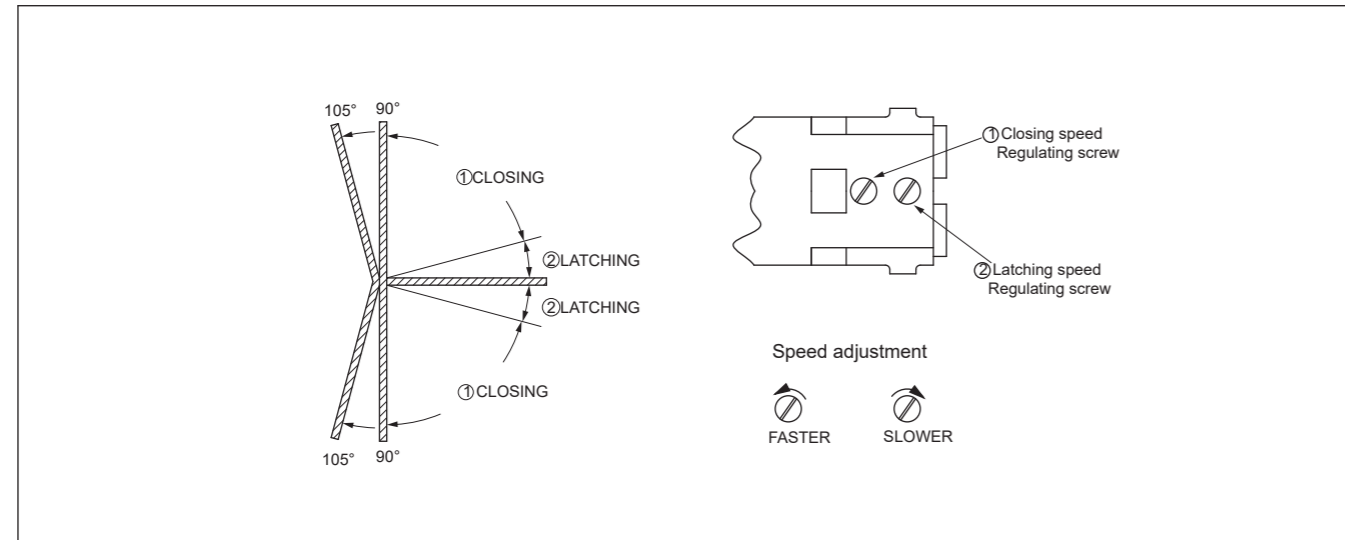

HEADERS & JAMBS

DOOR HEADED

Drill and counter-sink outside top surface for 10-32x8.5(M5x0.8) and 1/4-20x1-1/4"(M6x1.0) flat head screws as shown.

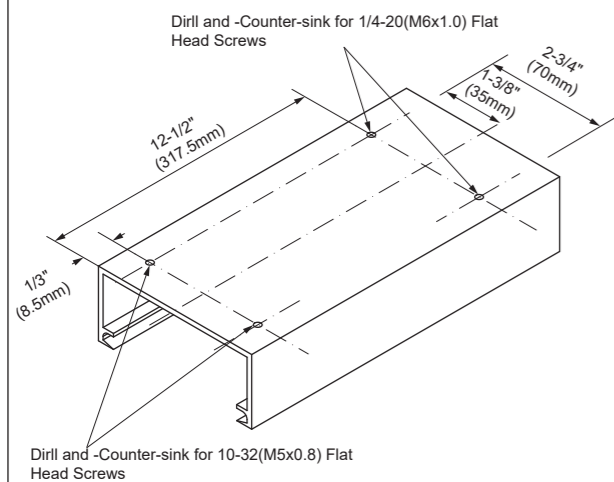

COVER PLATE

Drill 1-3/4"(44.5mm) hole as shown. Drill 1/2"(12.5mm) hole as shown.

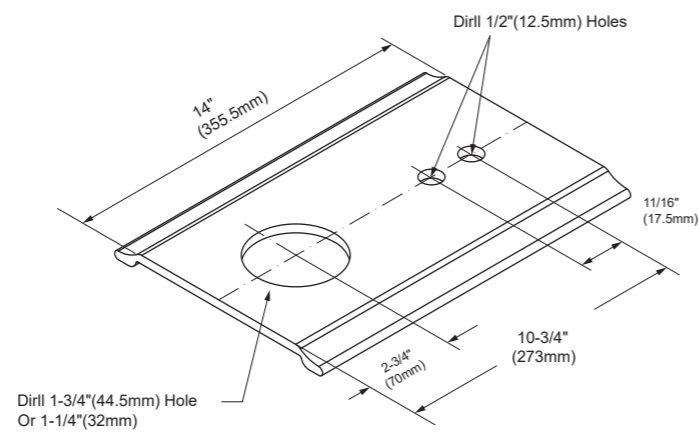

HINGE JAMB

Drill holes for #10 pan head self-threading screws as shown.

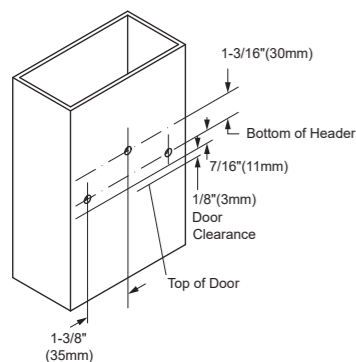

Install anchor using #10 x 9/16" pan head self-threading screws.

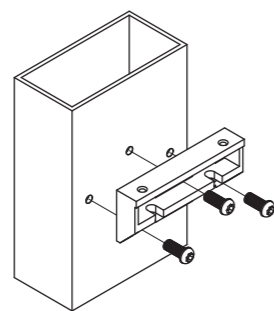

Mount door header on anchor using 10-32 x 7/16" flat head self-tapping screws.

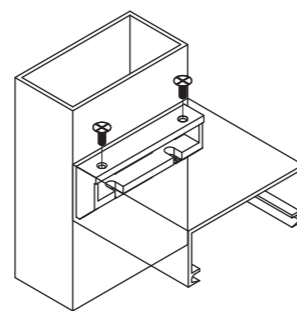

SIDE LOADING

TOP DOOR RAIL

"S" Type Side Loading Arm

Drill or drill and tap holes in top of door as shown.

Make 2-1/4"x1/2"(57mmx12.5mm) cut-out in top of door as shown. Cut-out must be on the inside of the door. Install arm using 1/4-20x1-1/4"(M6x1.0) flat head machine screw and 7/8" washer. Install 1/2-13x3/4"(M12x1.75) arm stud and 1/4-20x1-1/8"(M6x1.0) dome head arm adjustment screw. Laterally adjust center of the arm spindle retainer 2-5/8"(66.5mm) from hinge edge of door (not including weatherstripping). Center arm in the top rail by adjusting the two 1/4-20x1"(M6x1.0) hex head centering bolts.

After installation of door, attach dress plate with self-threading screws.

NOTE: Before attaching dress plate, make certain the three 1/4-20x7/8"(M6x1.0) socket head clamp bar screws with lock washers are tightened securely.

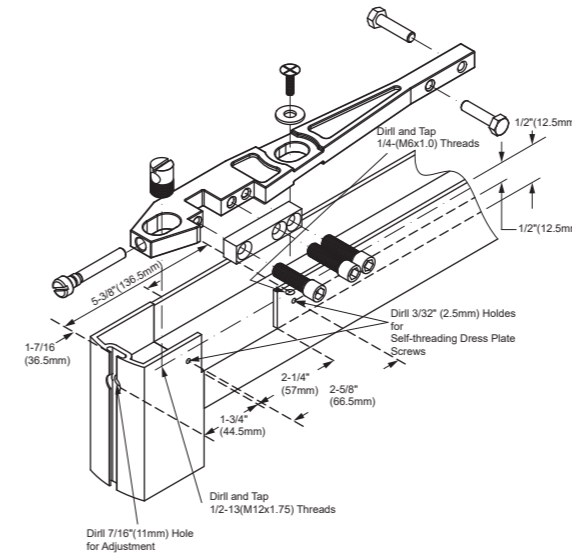

BOTTOM DOOR RAIL

Side Loading

Drill and tap 1/4-20 (M6x1.0) holes in bottom rail of door as shown. Install pivot bearing retainer in bottom of door using 1/4-20x5/8"(M6x1.0) pan head machine screws and lock washers.

Laterally adjust center of pivot bearing retainer 2-5/8"(66.5mm) from hinge edge of door (not including weatherstripping) and tighten screws securely.

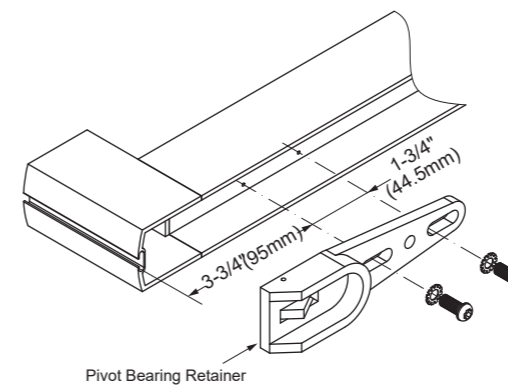

THRESHOLD MOUNT SET

Drill hole in threshold as shown. Install pivot stud and bearing with hex lock nut as shown and adjust bearing height for proper door clearance and firmly tighten lock nut.

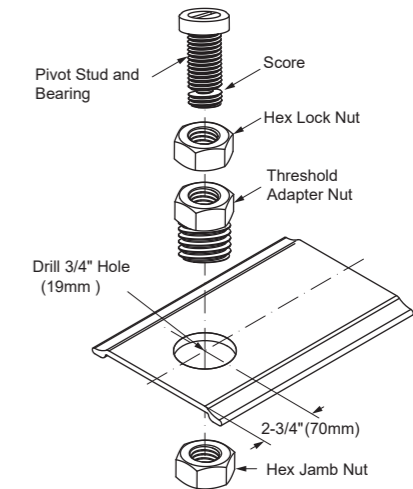

FLOOR MOUNT PIVOT

Center pivot base against door jamb on hinge side. Mark and drill 1/4"(6.5mm) holes 1-1/2"(38mm) deep in floor for plastic expansion plugs.

Mount base using #12x1/4" plastic expansion plugs #12x1/4" flat head wood screws. Install pivot stud and bearing with hex lock nut as shown, and adjust bearing height for proper door clearance and firmly tighten lock nut.

When using threshold, drill 1/4" (32mm) hole for clearance of pivot base on center line 2-3/4" (70mm) from hinge end of threshold.

NOTE: When threshold is not used, pivot bearing stud must be shortened by sawing off at score 1/2" (12.5mm) from bottom.

